

**GENERAL NOTES**

**REINFORCED CONCRETE PIPE**

- ADEQUATE COVER SHALL BE PROVIDED DURING CONSTRUCTION TO PROTECT THE PIPE FROM DAMAGE. THE MINIMUM COVER SHALL BE AS SHOWN ON THESE TABLES OR CONFORM TO AASHTO REQUIREMENTS, WHICHEVER IS GREATER. THE MINIMUM COVER FOR REINFORCED CONCRETE PIPE IS MEASURED FROM THE TOP OF THE PIPE TO THE BOTTOM OF THE PAVEMENTS (HMA OR PCCP).
- FILL HEIGHTS GREATER THAN MAXIMUM ALLOWED IN THE HEIGHTS OF FILL TABLE ON THIS SHEET REQUIRE SPECIAL DESIGN OF STRUCTURE.
- PIPE DESIGN IS BASED ON SAFETY FACTOR OF 1.33 ON ULTIMATE STRENGTH.
- THE HEIGHTS OF FILL OVER TOP OF PIPE ARE BASED ON UNIT WEIGHT OF SOIL AT 135 LBS. PER CUBIC FT.
- PIPE CLASS IS DETERMINED FROM 0.01 IN. CRACK D-LOAD.
- BEDDING IS CLASS B (MODIFIED) (FROM CONCRETE PIPE DESIGN MANUAL-AMERICAN CONCRETE PIPE ASSOCIATION) WITH SETTLEMENT RATIO  $R = 0.0_{gd}$  (YIELDING BED). BEDDING MATERIAL FOR RIGID PIPE IN SOIL SHALL BE 3 IN. LOOSE THICKNESS STRUCTURE BACKFILL CLASS 2. BEDDING MATERIAL FOR RIGID PIPE IN ROCK SHALL BE 12 IN. LOOSE THICKNESS STRUCTURE BACKFILL CLASS 1.
- CHANGES IN DESIGN FACTORS REQUIRE COMPENSATING CHANGES IN PIPE DESIGN.
- MINIMUM WALL THICKNESS DIMENSIONS ARE BASED ON AASHTO M 170 (WALL B) FOR CIRCULAR PIPE, AND AASHTO M 207 FOR ELLIPTICAL PIPE.
- SPACING FOR MULTIPLE PIPE INSTALLATIONS SHALL CONFORM TO THE DETAILS SHOWN ON STANDARD PLAN M-206-1.
- WHEN A PIPE IS TO BE EXTENDED, THE SAME PIPE MATERIAL AND SIZE AS IN THE ORIGINAL PIPE INSTALLATION SHALL BE USED.

**NONREINFORCED CONCRETE PIPE**

- AT THE OPTION OF THE CONTRACTOR, NONREINFORCED CONCRETE PIPE CONFORMING TO AASHTO M 86 MAY BE USED IN LIEU OF REINFORCED CONCRETE PIPE FOR ALL SIZES 36 INCHES IN DIAMETER AND SMALLER. THE NONREINFORCED CONCRETE PIPE SHALL MEET THE SAME D-LOAD TO PRODUCE THE ULTIMATE LOAD UNDER THE THREE-EDGE BEARING METHOD AS SPECIFIED FOR REINFORCED CONCRETE PIPE IN CONFORMANCE WITH AASHTO M 170. THE CONTRACTOR SHALL PROVIDE WRITTEN CERTIFICATION OF CONFORMANCE. THE WALL THICKNESS OF THE NONREINFORCED PIPE MAY BE INCREASED AS REQUIRED TO MEET D-LOAD REQUIREMENT.
- ALL REQUIREMENTS FOR REINFORCED CONCRETE PIPE, EXCEPT THOSE REFERRING TO REINFORCEMENT, SHALL APPLY TO NONREINFORCED CONCRETE PIPE.

CIRCULAR (CIR)			VERTICAL ELLIPTICAL (VE)				HORIZONTAL ELLIPTICAL (HE)			
PIPE SIZE = $Ba$ (INSIDE DIA)	WALL THICKNESS	$0.3 Bc$ (OUTSIDE DIA)	SPAN	RISE	WALL THICKNESS	0.3 OUTSIDE RISE	SPAN	RISE	WALL THICKNESS	0.3 OUTSIDE RISE
IN.		FT.	IN.				IN.			
			FT.				FT.			
12	2	0.40					23	14	2-3/4	0.49
15	2-1/4	0.49								
18	2-1/2	0.58								
21	2-3/4	0.66								
24	3	0.75					30	19	3-1/4	0.66
27	3-1/4	0.84					34	22	3-1/2	0.73
30	3-1/2	0.92					38	24	3-3/4	0.79
33	3-3/4	1.01								
36	4	1.10	29	45	4-1/2	1.35	45	29	4-1/2	0.95
42	4-1/2	1.28	34	53	5	1.58	53	34	5	1.10
48	5	1.45	38	60	5-1/2	1.78	60	38	5-1/2	1.23
54	5-1/2	1.62	43	68	6	2.00	68	43	6	1.38
60	6	1.80	48	76	6-1/2	2.23	76	48	6-1/2	1.53
66	6-1/2	1.97	53	83	7	2.43	83	53	7	1.68
72	7	2.15	58	91	7-1/2	2.65	91	58	7-1/2	1.83
78	7-1/2	2.32	63	98	8	2.85	98	63	8	1.98
84	8	2.50	68	106	8-1/2	3.08	106	68	8-1/2	2.13
90	8-1/2	2.68	72	113	9	3.28	113	72	9	2.25
96	9	2.85	77	121	9-1/2	3.50	121	77	9-1/2	2.40
102	9-1/2	3.02	82	128	9-3/4	3.69	128	82	9-3/4	2.54
108	10	3.20	87	136	10	3.90	136	87	10	2.68

△ ALSO EQUIVALENT ROUND DIMENSION FOR ELLIPTICAL PIPE.

**DIMENSIONS FOR REINFORCED CONCRETE PIPE**

(FOR INFORMATION ONLY)

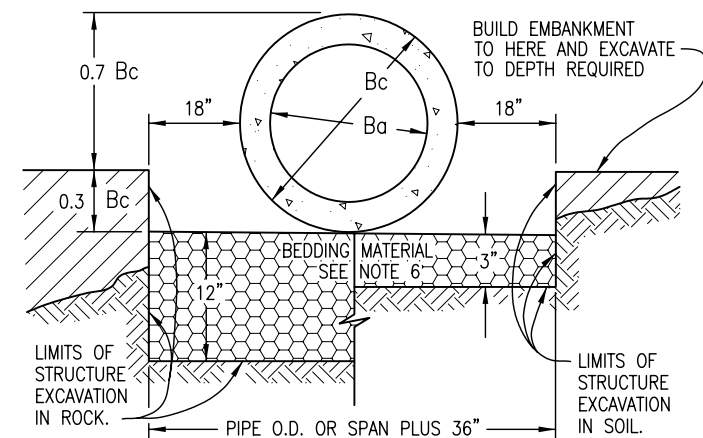

NOTE:  $Bc$  IS THE OUTSIDE DIMENSION FOR DIAMETER, SPAN OR RISE.

**PIPE INSTALLATION**

(WITH 0.7 PROJECTION RATIO)

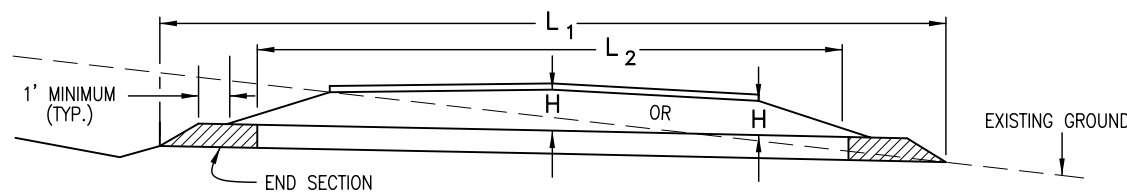

**CONCRETE PIPE WITH END SECTIONS**

NOTE: USE THE  $H$  THAT IS GREATER FOR MAXIMUM ALLOWABLE FILL HEIGHT.

- $H$  = MAXIMUM HEIGHT OF FILL OVER TOP OF PIPE, EXCLUDING PAVEMENT THICKNESS.
- $L_1$  = LENGTH OF PIPE TO BE MEASURED WHEN PLACED IN ACCORDANCE WITH SECTION 617 OR 624.
- $L_2$  = LENGTH OF PIPE TO BE MEASURED WHEN PLACED IN ACCORDANCE WITH SECTION 603.

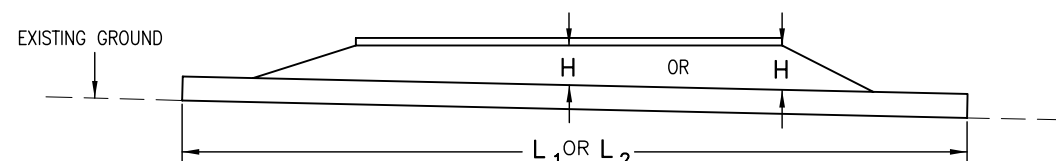

**CONCRETE PIPE WITHOUT END SECTIONS**

NOTE: USE THE  $H$  THAT IS GREATER FOR MAXIMUM ALLOWABLE FILL HEIGHT.

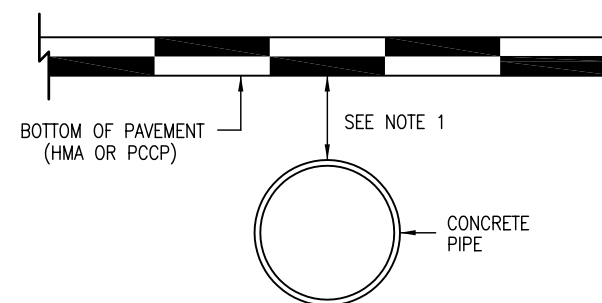

**MINIMUM COVER FOR RIGID PIPE**

TYPE OF PIPE	HEIGHT OF FILL OVER TOP OF PIPE, $H$ (FEET)				
	CLASS OF PIPE (0.01 IN. CRACK D-LOAD)				
	CLASS CIR II CLASS VE II CLASS HE II 1000 D	CLASS CIR III CLASS VE III CLASS HE III 1350 D	CLASS CIR IV CLASS VE IV CLASS HE IV 2000 D	CLASS CIR V CLASS VE V 3000 D	CLASS VE VI 4000 D
CIRCULAR (CIR)	MIN. TO 18	MIN. TO 25	± 25 TO 37	± 37 TO 45	
VERTICAL ELLIPTICAL (VE)	MIN. TO 18	MIN. TO 25	± 25 TO 37	± 37 TO 45	± 45 TO 62
HORIZONTAL ELLIPTICAL (HE)	MIN. TO 18	MIN. TO 25	± 25 TO 37		

**ALLOWABLE RANGE OF HEIGHTS FOR FILL OVER REINFORCED CONCRETE PIPE**

(ALL SIZES)

<b>Computer File Information</b> Creation Date: 07/04/06      Initials: SJR Last Modification Date: 07/04/06      Initials: LTA Full Path: www.dot.state.co.us/DesignSupport/ Drawing File Name: 603020101.dwg CAD Ver.: MicroStation V8      Scale: Not to Scale      Units: English		<b>Sheet Revisions</b> Date:      Comments:		Colorado Department of Transportation  4201 East Arkansas Avenue Denver, Colorado 80222 Phone: (303) 757-9083 Fax: (303) 757-9820 Project Development Branch      SRJ/LTA		<b>REINFORCED CONCRETE PIPE</b> Issued By: Project Development Branch on July 04, 2006		<b>STANDARD PLAN NO.</b> M-603-2 Sheet No. 1 of 1	
--	--	--	--	--	--	---	--	---	--